

# Model 3028 Accelerometer

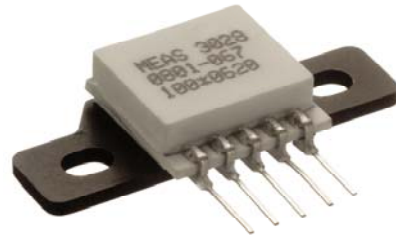

Piezoresistive MEMS  
DC Response, mV Output  
Low Cost  
Screw Mounted Flange



The **Model 3028** is a silicon MEMS accelerometer in a Wheatstone bridge configuration. It is packaged on a ceramic substrate with a metal bracket which can be used to bolt the sensor to the mounting location. The accelerometer is offered in ranges from  $\pm 2g$  to  $\pm 200g$  range and provides a flat frequency response to minimum 2000Hz. The silicon MEMS sensor is gas damped and incorporates over-range stops for high-g shock protection.

For a similar accelerometer designed for adhesive mounting, see the model 3022.

## dimensions

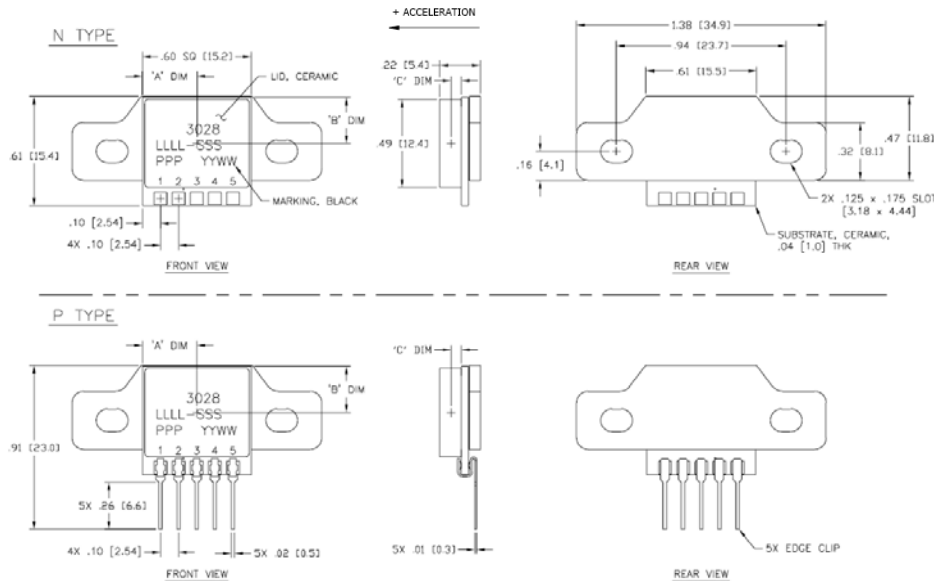

## FEATURES

- Bolt Mounted
- $\pm 0.5\%$  Non-linearity
- Open Wheatstone Bridge
- DC Response
- Gas Damping
- Built-in Overrange Stops
- Low Power Consumption

## APPLICATIONS

- Vibration & Shock Monitoring
- Motion Control
- Impact & Shock Testing
- Modal Analysis
- Embedded Applications
- Machinery

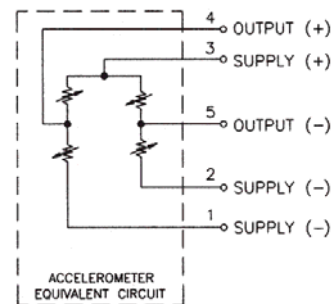

# Model 3028 Accelerometer

## performance specifications

All values are typical at +24°C, 100Hz and 5Vdc excitation unless otherwise stated. Measurement Specialties reserves the right to update and change these specifications without notice. Standard product parameters are described in PSC-1002 for Embedded DC Accelerometers.

### Parameters

#### DYNAMIC

	±2	±5	±10	±20	±50	±100	±200	Notes
Range (g)								
Sensitivity (mV/g) <sup>1</sup>	8.0-20.0	6.0-15.0	3.0-6.0	1.5-3.0	0.6-1.5	0.3-0.6	0.15-0.3	@5Vdc Excitation
Frequency Response (Hz)	0-150	0-250	0-400	0-600	0-1000	0-1500	0-2000	±5%
Natural Frequency (Hz)	700	800	1000	1500	4000	6000	8000	
Non-Linearity (%FSO)	±0.5	±0.5	±0.5	±0.5	±0.5	±0.5	±0.5	
Transverse Sensitivity (%)	3	3	3	3	3	3	3	
Damping Ratio	0.7	0.7	0.7	0.7	0.7	0.7	0.6	
Shock Limit (g)	5000	5000	5000	5000	5000	5000	5000	

#### ELECTRICAL

Zero Acceleration Output (mV)	±25	±25	±25	±25	±25	±25	±25	Differential
Excitation Voltage (Vdc)	2 to 10	2 to 10	2 to 10	2 to 10	2 to 10	2 to 10	2 to 10	
Input Resistance (Ω)	2500-6500	2500-6500	2500-6500	2500-6500	2500-6500	2500-6500	2500-6500	
Output Resistance (Ω)	2500-6500	2500-6500	2500-6500	2500-6500	2500-6500	2500-6500	2500-6500	
Insulation Resistance (MΩ)	>100	>100	>100	>100	>100	>100	>100	@50Vdc
Residual Noise (μV RMS)	10	10	10	10	10	10	10	Maximum
Ground Isolation	Isolated from Mounting Surface							

#### ENVIRONMENTAL

Thermal Zero Shift (%FSO/°C)	-0.09	-0.09	-0.09	-0.09	-0.09	-0.09	-0.09	Typical
Thermal Sensitivity Shift (%/°C)	-0.15	-0.15	-0.15	-0.15	-0.15	-0.15	-0.15	Typical
Operating Temperature (°C)	-40 to +125							
Compensated Temperature (°C)	Not Compensated							See Note 2
Storage Temperature (°C)	-40 to +125							

#### PHYSICAL

Case Material	Aluminum Flange, Ceramic Cover
Weight (grams)	4.5
Mounting	2x #4-40 Mounting Screws
Mounting Torque	6 lb-in (0.7 N-m)

<sup>1</sup> Output is ratiometric to excitation voltage

<sup>2</sup> Order model 3028-XXX-10256 for temperature compensation resistor values included in the calibration certificate.

The information in this sheet has been carefully reviewed and is believed to be accurate; however, no responsibility is assumed for inaccuracies. Furthermore, this information does not convey to the purchaser of such devices any license under the patent rights to the manufacturer. Measurement Specialties, Inc. reserves the right to make changes without further notice to any product herein. Measurement Specialties, Inc. makes no warranty, representation or guarantee regarding the suitability of its product for any particular purpose, nor does Measurement Specialties, Inc. assume any liability arising out of the application or use of any product or circuit and specifically disclaims any and all liability, including without limitation consequential or incidental damages. Typical parameters can and do vary in different applications. All operating parameters must be validated for each customer application by customer's technical experts. Measurement Specialties, Inc. does not convey any license under its patent rights nor the rights of others.

## ordering info

PART NUMBERING Model Number+Range+Electrical Connection

3028-GGG-P  
 | |  
 | | Electrical Connection (P=pins, N=solder pads)  
 | Range (010 is 10g)

Example: 3028-010-P  
 Model 3028, 10g, Pins

北京汇润科贸有限公司

电话：+ 86 010 5601 8989

+ 86 010 5601 7979

传真：+ 86 010 5885 7266

邮箱：[sales@aq315.com](mailto:sales@aq315.com)

<http://www.aq315.com>